

# Series 3000

## Multipoint Recorder

### The future in Data Recording Technology is available today

The Series 3000 Recorder represents a powerful combination of microprocessor technology and real-time multi-tasking software to provide you with an extremely versatile data acquisition tool. This recorder integrates the functions of a data logger, multipoint recorder, alarm annunciator, and digital indicator into a single instrument. With just a few keystrokes (guided by unique menu driven prompts), you can change a variety of functions such as: input types, alarm setpoints, chart speeds, and many other customer defined parameters required to meet your specific application requirements.

The Series 3000 Recorder is available in three basic direct input capacity configurations: 16, 32, or 64. Any combination of thermocouples, RTD'S, current, and voltage can be monitored simultaneously. All three configurations provide a maximum of 99 total points.

The user can select up to ten colors to enhance the chart readability by color matching traces and scales. Points in alarm are highlighted in red on all log printouts and in the right hand margin. If selected, trend lines will also turn red automatically when the point goes into alarm.

The instrument features EEPROM configuration back-up which allows you to re-customize the instrument to new application requirements and save the new configuration. This feature eliminates the need for battery backup.



## Features

- Up to 64 direct inputs and 99 total points
- On-board capability to do mathematical calculations including peak/valley and selectable time averages, totalization, and enhanced math capabilities -- powers, roots, log, anti-log, conditional (Boolean) calculations, and sterilization ( $F_0$ ) factors
- Up to 4 Meg on board, solid-state history available
- Up to ten programmable color traces and scales
- Switch selectable RS232C, RS485, RS422, or 20mA communication available
- Selectable Modbus™ or ASCII compatible protocol
- 8, 16, 24, 32, or 48 Form C alarm contacts available
- IEEE-344 1987 Seismic qualification available

## Modes of Operation

The Series 3000 Recorder integrates the functions of a multipoint recorder, data logger, alarm annunciator, and digital indicator into a single instrument. Two different modes of operation support these capabilities: Trend Mode and Log Mode.

**Trend Mode** - Graphically trends points on chart paper at the selected chart speed. When operating in the Trend Mode, you have the following trending operations - Trend by Point, Trend by Group, or Trend on Alarm. (See Sample Trend Mode Chart Printout on page 4.) Any preprogrammed Data Logs will also be printed.

**Log Mode** - Automatically prints an Alarm Status Log that lists the time, measured value, engineering unit, alarm status and legend of each point that goes into and out of alarm. Any preprogrammed Time-of-Day or Interval Logs will also be printed.

*** STATUS CHANGE 09:07:41	01	1.00E+38	DEG F	HH	EXHAUST TEMP	***
*** STATUS CHANGE 09:07:36	24	610.0	DEG F	HI	HEAT EXCHANGER DIFF	***
*** STATUS CHANGE 09:07:36	14	-314.0	PCT.	LL	UNIT 2 OPACITY	***
*** STATUS CHANGE 09:07:36	02	1.00E+38	DEG F	HI	PREHEAT TEMP	***
**** 09:00:06					APR 24, 96	****
*** STATUS CHANGE 08:49:56	26	-1500.0	PCT.		EFFICIENCY	***
*** STATUS CHANGE 08:49:51	26			OVFL	EFFICIENCY	***
*** STATUS CHANGE 08:41:56	16	29.0	PCT.		AVERAGE OPACITY	***
*** STATUS CHANGE 08:41:31	27	-1000.0	PCT.		OPACITY	***
*** STATUS CHANGE 08:41:26	27			OVFL	OPACITY	***
*** STATUS CHANGE 08:40:36	14	10.0	PCT.	LL	UNIT 2 OPACITY	***
*** STATUS CHANGE 08:39:46	14	20.0	PCT.	LO	UNIT 2 OPACITY	***
*** STATUS CHANGE 08:38:36	14	34.0	PCT.		UNIT 2 OPACITY	***
*** STATUS CHANGE 08:36:16	01	1.00E+38	DEG F	HH	EXHAUST TEMP	***
*** STATUS CHANGE 08:36:11	24	610.0	DEG F	HI	HEAT EXCHANGER DIFF	***
*** STATUS CHANGE 08:36:11	16	63.5	PCT.	HI	AVERAGE OPACITY	***
*** STATUS CHANGE 08:36:11	14	63.0	PCT.	HI	UNIT 2 OPACITY	***
*** STATUS CHANGE 08:36:11	02	1.00E+38	DEG F	HI	PREHEAT TEMP	***
*** STATUS CHANGE 08:36:01	01	1.00E+38	DEG F	HH	EXHAUST TEMP	***
*** STATUS CHANGE 08:35:56	24	610.0	DEG F	HI	HEAT EXCHANGER DIFF	***
*** STATUS CHANGE 08:35:56	16	94.0	PCT.	HI	AVERAGE OPACITY	***
*** STATUS CHANGE 08:35:56	14	66.0	PCT.	HI	UNIT 2 OPACITY	***
*** STATUS CHANGE 08:35:56	02	1.00E+38	DEG F	HI	PREHEAT TEMP	***

Sample Log Mode Alarm Status Log Printout

## DISPLAY Key - Monitor your process at a glance . . .

The DISPLAY key enables the selection of any one of the several menu functions to be displayed on the Vacuum Fluorescent Display. Operating in either the Trend Mode or Log Mode, the following menu functions can be selected for monitoring:

**POINT?** - The point number selected is displayed and updated at the programmed display rate. Point data parameters that may be displayed consist of: Point Number (or Legend), Engineering Units, and Alarm Status. The display will also indicate when the Point Number selected is: Not Found, Bypassed, TCBO (Thermocouple Burn-out), Invalid, Overflow, and Overrange (measured data exceeds boundaries of T/C or RTD Linearization Table).

**TIME** - This function displays the time and date in the following format: HH (hours in 24 hour format) = MM (minutes) = SS (seconds) MMM (month abbreviated to 3 letters) DD (day), YY (year). The current time and date are updated at the programmed display rate.

**ALARMS** - Alarm points are sequentially scrolled at the programmed display rate. If no points are in alarm, the display will read NO ALARMS PRESENT.

**GROUP** - All points programmed to the selected group will be sequentially scrolled at the programmed display rate. If no points are assigned to the selected group, the display will read NO POINTS IN GROUP.

**LEGEND** - The 20-character programmed legend of the selected point is displayed.

**SETPOINTS** - The programmed alarm setpoints (HH, H, L, LL) and Rate Alarm (RT) of the selected point are displayed.

**CHART SCALE (Trend Mode Only)** - The programmed chart scale limits, engineering units, and color assignments will be displayed.

**CHART SPEED (Trend Mode Only)** - The current operating chart speed is displayed.

**VERSION** - The software number, base version, release number, and date of release is displayed.

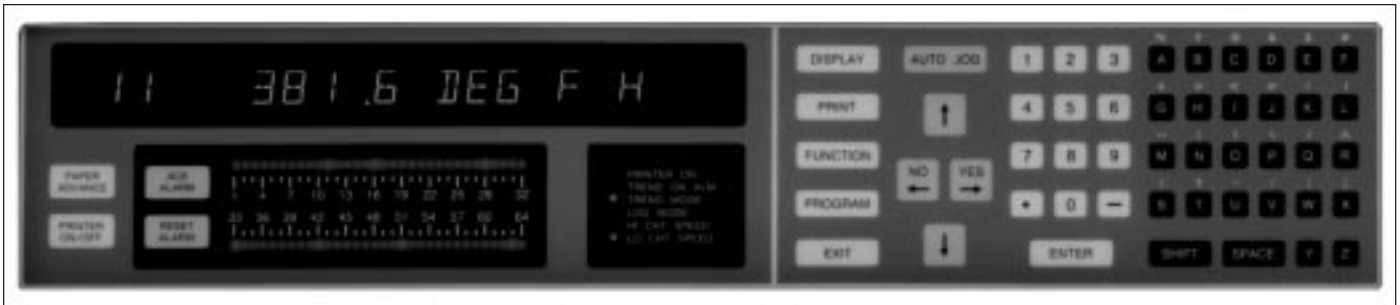

Most commonly used controls and indicators required to program and operate the instrument are conveniently located on the Operator Control panel.

## PRINT Key - Document the process . . .

In the Trend or Log Mode, the PRINT key allows the user to access a list of menu items for information to be burst printed on the chart.

**ALL POINTS** - Activating this menu initiates the All Points Log to be printed across the chart in four columns, with a header and a title. If a point is bypassed or cannot be measured correctly, an error message will print in place of data. Points in alarm are printed in red.

**ALARMS** - Activating this menu will print all points in an alarm state in red. If there are no points in alarm, the message NO ALARMS PRESENT, the time, and date are printed across the chart.

**GROUP** - Entering this menu and the appropriate group number (1 through 8), will print all of the points assigned to

the selected group in a four column format. The title of the log reads LOG GROUP, Unit ID, start and end time, and date.

**MESSAGE** - Activating this menu item allows a 20-character Event Message to be printed on demand. The user can print any of 16 programmed Event Messages or print unique messages programmed under the PRINT Key menu.

**PROGRAM** - Activating this menu will burst print a table across the chart that lists all the programmed parameters of each point in the database. The following parameters (columns) are printed for each point: Point Number, Legend, Function Code, Scale Low End Parameter, Scale High End Parameter, Input Low End, High End, Engineering Units, Trend Point, Zone Point, Scale,

Color, Group, Alarm Set-point, Deadband, Alarm Contact, and Relay Number.

**PROFILE** - A Log Profile consists of all SYSGEN and non-point related program parameters. Parameters listed include: Unit ID, Software Version, Version Number and Date, Measurement Control, Alarm Contact Control, Chart Control, Chart Scale, Unprotected Functions, Protected Functions, SIO Control, and Point Status Symbols.

**CANCEL** - This function cancels the printing of any log currently in progress. Since all printed data is sent to the PDC for processing, there will be a delay from the time the cancel command is activated until the time the printing actually stops. A LOG CANCELED message is printed before termination of the log.

## FUNCTION Key - Change parameters without reprogramming . . .

The FUNCTION Key gives the user the option to change certain previously programmed parameters without reprogramming the unit. These parameters consist of:

**SELECT CHART SPEED** - This function, when AUTO SPEED function is turned off, enables the user to select between the programmed LO or HI chart speed.

**RESET A POINT** - This function resets the point types (LO PEAK, HI PEAK, TOTALIZE, MOVING AVERAGE, and TIME AVERAGE) to the current value of the base point and resets the filter count to zero.

**ACTIVATE A POINT** - Points that have been temporarily bypassed can be returned to the measurement cycle.

**BYPASS A POINT** - Active points can be removed from the measurement cycle. Points that have been bypassed, are still in the database, however, the message BYPASSED appears when the bypassed point is displayed or is printed.

**SELECT SCALE SET** - This function enables you to change between the user definable scale sets 1 and 2.

# PROGRAM Key - Straight forward and simple configuration. . .

The PROGRAM Key provides two separate programming modes - Startup Programming and Options Programming.

These modes provide the user with the necessary functions required to configure the instrument for initial start-up

operation and allows the user to enhance operational parameters to meet specific application needs.

## Start-up Mode - Configure the basic parameters required for operation . . .

**Date/Time** - Allows the user to set the recorder's internal clock for dependent features such as alarm annotation, selectable time averages, and log documentation.

**Program Point** - Allows the user to establish, modify, copy, or delete a point's parameters; e.g. input type (thermocouple, RTD, linear, calculated, and external data), decimal fix, input relay number, engineering units, alarm set-points, legend, and trend scale. With the Totalization option, the system allows a flow rate to be totalized.

**Chart Speed** - Allows the user to establish the Hi and Lo chart speeds of the recorder. These speeds are configurable from 0.5 in/hr to 60 in/hr or 5mm/hr to 1500mm/hr in the Metric Chart Speed mode.

**Chart Scales** - Allows the user to establish two sets of user definable chart scales that contain six scales each. A scale prints when a configured point is assigned to it. Each set is labeled 1 or 2 and the six scales assigned as A, B, C, D, E, and F. The menu prompts to establish the decimal fix, low and high end of the scale values, a color, and a five character user definable engineering unit for each scale. In the trend mode, each scale of the operating set is printed across the chart at preconfigured intervals in rotating fashion. An example of a chart scale matrix is shown to the right. Chart scales can be programmed to print in zones from 10% to 100% (in increments of 1%) of the chart paper.

### Example Chart Scale Matrix

SCALE	SET		ENG UNITS	DEC FIX	COLOR
	1	2			
A	0.0 to 100.0	50.0 to 100.0	DEG F	1	RED
B	10.00 to 50.00	0.00 to 100.00	RPM	2	GRN
C	4.0 to 20.0	25.0 to 100.0	PCT	1	BLU
D	0 to 500	10 to 50	GPM	0	BLK
E	0.0 to 1000.0	200.0 to 800.0	PSI	1	VIO
F	200 to -50	75 to -20	DEG C	0	ORG

**Chart Calibration** - Allows the user to calibrate the printhead's left and right chart paper margins using the Left and Right Arrow keys.

**Learn** - Performing a LEARN function transfers defined programming parameters from volatile memory (RAM) to nonvolatile memory (EEPROM).

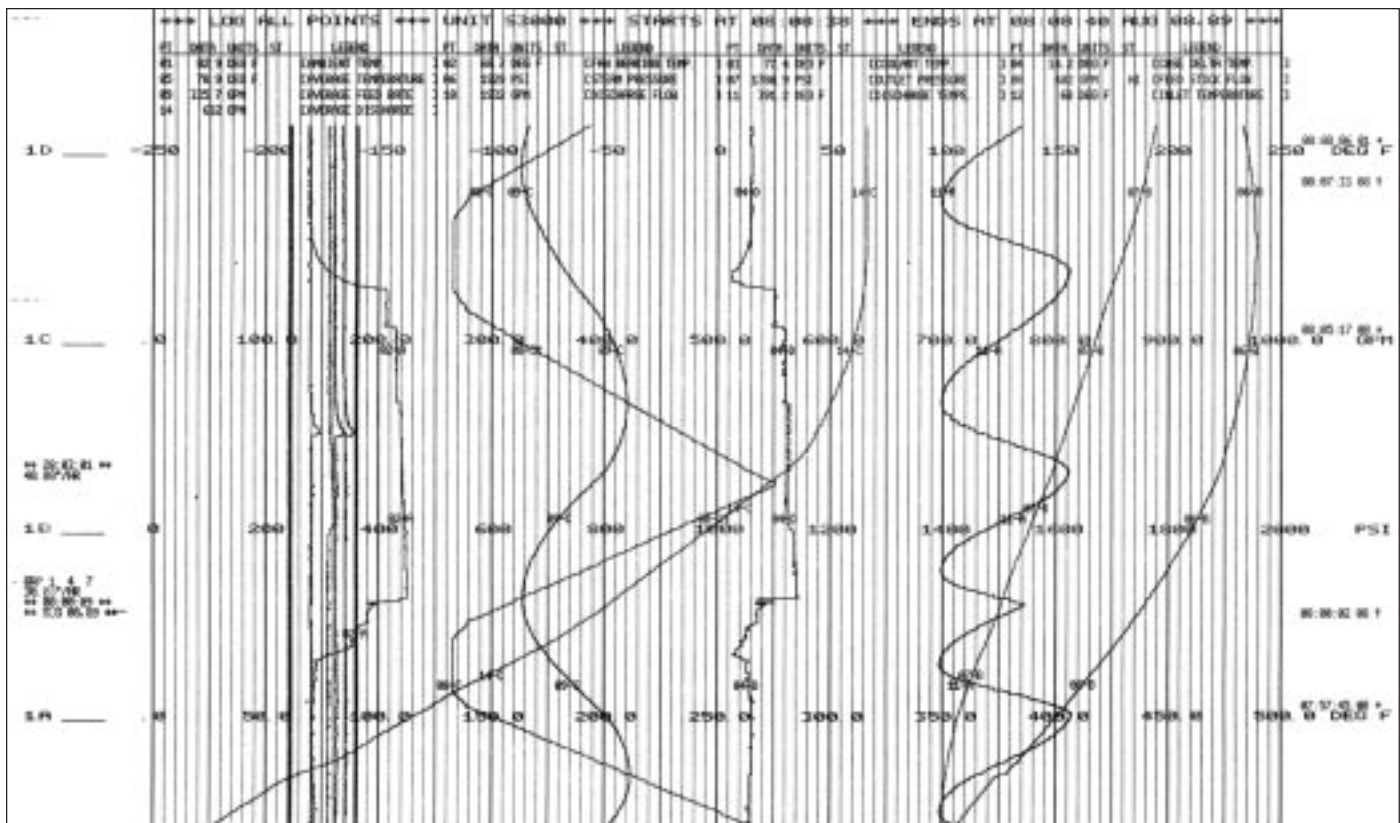

Sample Trend Mode Chart Printout



## Options Mode - Enhanced operations to fit each application . . .

**Color Assignment** - When in the Auto Assign Mode, each point is automatically assigned a color. When Auto Assign Mode is turned off, colors can be individually selected for each point.

**Trend/Log Control** - Configure the recorder to operate as a trend recorder or a data logger.

**Group Assignment** - Assign up to 99 points to any of eight groups. Grouping points allows display, auto jog, print, trend, log, or average specified points.

**Chart Zones** - Establish individual chart zones for each programmed chart scale (A, B, C, D, E, and F). Chart zones are programmed in 1% (2.5mm) increments from a minimum span of 10% to a maximum span of 100% (250mm).

**User Tables** - Define custom linearization tables for special input types.

**Alarm Check** - Activate or disable the alarm check monitoring function.

**Rate Alarm Check** - Activate or disable the rate alarm setpoints monitoring function.

**Scan Interval** - Define how often inputs are measured.

**Unit Identification** - Program a custom five-digit unit ID.

**SYSGEN** - Provides user with the ability to change the following system profile parameters of the instrument:

**Database Control** - Clears all points and initializes the system to factory default settings.

**SIO Control** - Sets communication interface parameters (Baud Rate, Stop Bits, Parity, Checksum, Network, Address, and Bits/Word). Sets protocol parameters: MODBUS™ or ASCII.

**Measure Control** - Sets operating mode (live or demo), sets the measure delay, and enable/disable span and offset (allows for correction of known errors in sensors).

**Contact Control** - Sets output contacts operation (e.g. Contact Reflash, Open Common Alarm Upon Acknowledgement, Open Common Alarm Upon Clearing, and Open Programmed Alarms Upon Acknowledgement).

**Thermocouple Control** - Enables tests for thermocouple burnout and establishes certain thermocouple parameters (thermocouple burnout test, thermocouple alarm, and thermocouple decimal format).

**Display Control** - Sets the display rate and determines one of two point display formats (Point Number and data or Legend and data).

**Chart Control** - Sets Scale ID (when ON, point number and chart scale ID letter printed), Alarm Trace (when ON, points in alarm are trended in red), ID Interval (trendable points identified at programmed interval), Scale Interval (can be programmed in increments of one to 12 inches in one inch increments), Auto Speed (allows recorder to trend at high speed when alarm activated), Standard/Metric Chart Speed (allows recorder to trend in inches or millimeters chart speed), Print Cycle (controls the printer rate for trend data), Ribbon Type (2 or 4-color; 2-color used for data logging applications only).

**Access Control** - Establishes a passcode to protect against unauthorized entry into the Function (four-digit code) and Program Key (up to six-digit code) menus.

**Utilities** - Run a "self-diagnostic" check on certain individual functions to aid in troubleshooting the unit. User can also calibrate the printer subsystem, adjust display intensity, and copy and translate databases.

**Interval Logs** - Allows for an Interval Log to print periodically at a user defineable time interval. This log can either be burst printed across the chart or printed in the left margin in 1, 2, 3, or 4-column formats.

**Alarm/TOD Logs** - Allows one Log on Alarm and four Time-of-Day (TOD) Logs to be programmed to occur automatically while operating in either the Trend or Log Mode, TOD Logs consist of All Points, Alarms, Alarm Groups, Program, Profile, and None.

**Calibrate ADC** - Provides menu driven prompts to enable calibration of the Analog-to-Digital Converter.

**Zone Mode** - In order to eliminate trace clutter, this function allows you to assign points with similar processed values to a zone. Points within the zone are not identified until they exit the zone boundaries. The point will continue to be identified until it reenters the zone.

**Event Messages** - With optional hardware, up to 16 20-character messages can be printed for eight contact outputs to indicate opening and closing of the contacts.

## Remote Control Options . . .

The Series 3000 Recorder has available several remote control options that enhance operation of instruments located in remote areas. These options include: Remote Alarm Acknowledge, Remote Alarm Reset, Remote Printer On/Off, Remote Scale Set Change, and Communications.

**Remote Alarm Acknowledge** - This option enables a momentary switch to be connected to appropriate terminals on the Rear Terminal Panel to duplicate the action of the ACK ALM key on the front control panel.

**Remote Alarm Reset** - This option enables a momentary switch to be connected to the appropriate terminals on the Rear Terminal Panel to duplicate the action of the RESET ALM key on the front control panel.

**Remote Printer On/Off** - This option enables a momentary switch to be connected to the appropriate terminals on the Rear Terminal Panel to turn the PRINTER ON or OFF.

**Remote Scale Set** - This option enables a momentary switch to be connected to the Rear Terminal Panel to

switch the Active Scale Set.

**Communication Interface** - An optional communication port provides the ability to communicate via RS232C, RS485, RS422, or 20mA. Communication protocol is selectable: Modbus™ or ASCII compatible. Data can be sent to or received from a Series 3000 Recorder for logging, trending and displaying from a computer or PLC. Messages can also be transmitted to the recorder for printing on the chart. Up to 31 Series 3000 Recorders can be connected via RS422 or RS485 interface to a PC.

## Software Options . . .

**Boolean Logic** - This option allows the user to program logic calculations such as: if, and, or, equal, not equal, greater than, less than, and alarm.

**Sterilization ( $F_0$ )** - This point type uses a Base Point, Reference Temperature, Z Constant, and Auto Reset to perform calculations for  $F_0$ .

**Totalization** - This option, configurable from the Program Point menu (Start-up Mode), allows for the flow rate of a material to be totalized. This flow rate can be measured in units per second, minute, hour, or day. The user can specify the decimal fix and whether to print the totalized value on the chart automatically when the total is reset. Totals can be reset manually, automatically, or through the communications interface.

**Solid-State History** - This option includes both software and hardware additions to the Series 3000 Recorder that enables the user to continuously store up to four megabytes of critical input data in memory. This option can be configured to log or trend the data only on alarm or other abnormal conditions. In addition, if the recorder is equipped with the communications option, the historical data can be accessed via the serial communications port.

**Historian Software** - This software package, free upon request to users of the Series 3000 Recorder, enables point data from the recorder to be stored in a personal computer (IBM or compatible). This data can be used to compile a history of each point, or used for data process functions such as graphing, or calculations. The Auto-start feature lets

the operator configure the time for automatic data retrieval to begin.

**Remote Programmer Software** - This software package is available, free upon request, to users of the Series 3000 Recorder. The Remote Programmer software allows the recorder, equipped with the communication interface option, to be programmed from a remote IBM PC, PC/XT, PC/AT, or compatible computer. It features pull down menu functions of the DISPLAY, PRINT, FUNCTION, and PROGRAM keys, a "Help" function, plus the ability to send messages to the instrument for printing. In addition, the Remote Programmer Software allows the user to store the entire program data base and system configuration on a standard floppy disk or hard drive for retrieval at a later time.

# Options . . .

The Series 3000 Recorder is available with an extensive list of options that will allow you to configure the instrument to best meet your specific application requirements. These options also are available as field installable kits.

- High Accuracy 10 Ohm Cu RTD (Current Source MUX Board 16 or 32 Pts.)
- 64-Point Alarm Status Indicator
- Relay Contact Outputs: 8, 16, 24, 32, or 48 Form C with the following contact ratings:
  - Standard - 1 amp at 117Vac or 26Vdc for resistive loads
  - EMI Hardened - 1 amp at 117Vac +/-10%; 0.5 amp at 230Vac +/-10%; or 0.4 amp at 250Vdc for resistive loads
- Communication Interface (RS232C/20mA and RS232C/RS422/RS485)
- Event Messages
- 3/4 Door
- Door Lock
- Nonglare Window
- Legend Plate
- Fluorescent Lighting
- Power Cord
- Terminal Blocks for Input Terminal Shields (16 & 32 point version)
- Stainless Steel Tag
- Carrying Handles
- 50 Ohm Current Shunt (For 4 to 20 Inputs)
- Two-Wire Transmitter Power Supply (640mA)
- Factory Point Programming
- EMI/RFI (CE Mark Certification)
- Seismic (IEEE 344, 1987) Certification
- Software V & V

**Seismic and EMI/RFI Test Reports available on request**

## How To Order

In order to determine the model configuration needed, choose one item from each group (A through O) of the Model Selection Chart and write the selected number on the appropriate line in the Model Number Summary below. However, it is recommended that you contact Westronics Sales Office for specific order information before placing an order.

### Model Selection Chart

<b>A</b>	1	16 Direct Inputs	<b>POINT CAPACITY</b>	<b>G</b>	0	Customer Data Base	<b>POINT PROGRAMMING</b>		
	2	32 Direct Inputs			1	Factory Data Base			
	4	64 Direct Inputs							
<b>B</b>	1	Voltage, Current, RTD, Thermocouple Inputs and Basic Math	<b>OPERATING SOFTWARE</b>	<b>H</b>	1	3/4 Door	<b>OPTION GROUP 1</b>		
	2	Item 1 and 10 ohm RTD			2	3/4 Door with Lock			
	3	Item 1, Totalization, Sterilization, Enhanced Math, Conditionals and Log			3	Full Door			
	4	Item 3 and 10 Ohm Cu RTD			4	Full Door with Lock			
	5	Item 1, Enhanced Math, Log, and Conditionals			<b>I</b>	0		None	<b>OPTION GROUP 2</b>
	6	Item 5 and 10 Ohm Cu RTD				1		Fluorescent Lighting	
<b>C</b>	1	117Vac/60Hz	<b>INPUT POWER</b>	<b>J</b>	2	Nonglare Window/Fluorescent Lighting	<b>OPTION GROUP 3</b>		
	2	117Vac/50Hz			3	Legend Plate (64 Point)			
	3	230Vac/50Hz			4	Nonglare Window/Fluorescent Lighting/Legend Plate			
	4	230Vac/60Hz			5	Fluorescent Lighting/Legend Plate			
<b>D</b>	0	No	<b>ALARM INDICATOR</b>	<b>K</b>	0	None	<b>OPTION GROUP 4</b>		
	1	Yes			1	Power Cord (117Vac Only)			
<b>E</b>	1	One Common Alarm (CA)	<b>RELAY CONTACT OUTPUT/ EVENT MARKER INPUT</b>	<b>L</b>	2	Terminal Blocks - Input Terminal Shields		<b>OPTION GROUP 5</b>	
	2	One CA + 8 Std. Contact Outputs (SCO) with Remote Alarm Acknowledge/Reset (RAA/R)			3	Terminal Shields - Input Items 1 & 2			
	3	One CA + 16 SCO/RAA/R			0	None			
	4	One CA + 8 EMI-Hardened Contact Outputs (EMI-HCO) with RAA/R			1	50 Ohm Shunt (4 to 20 or 10 to 50mA)			
	5	One CA + 16 EMI-HCO/RAA/R			2	Two-wire Transmitter Power Supply			
	6	One CA + 24 SCO/RAA/R			3	Items 1 & 2			
	7	One CA + 24 EMI-HCO/RAA/R			<b>M</b>	0	None		<b>OPTION GROUP 6</b>
	8	One CA + 8 Event Marker Inputs (EvMkIn)				1	Seismic (IEEE 344, 1987) Test Report and Certificate of Compliance		
	9	One CA + 8 EvMkIn & 8 SCO with RAA/R				3	EMI/RFI (CE Mark Certification)		
	A	One CA + 8 EvMkIn & 16 SCO with RAA/R				4	Items 1 & 2		
	B	One CA + 8 EvMkIn & 8 EMI-HCO with RAA/R				5	Items 1 & 2 and Software V & V		
<b>F</b>	C	One CA + 8 EvMkIn & 16 EMI-HCO with RAA/R	<b>COMMUNICATION INTERFACE</b>	<b>N</b>	0	None	<b>OPTION GROUP 7</b>		
	D	One CA + 32 SCO with RAA/R			X	Special			
	E	One CA + 32 EMI-HCO with RAA/R			<b>O</b>	0		None	<b>OPTION GROUP 8</b>
	F	One CA + 8 EvMkIn & 32 SCO with RAA/R				1		Solid-State History, .5 Meg	
	G	One CA + 8 EvMkIn & 32 EMI-HCO with RAA/R				2		Solid-State History, 1 Meg	
	H	One CA + 48 SCO with RAA/R				3		Solid-State History, 2 Meg	
	I	One CA + 48 EMI-HCO with RAA/R				4		Solid-State History, 4 Meg	

### Model Number Summary

3000 -      -      -      -      -      -      -      -      -      -     

A B C      D E F      G H I      J K L      M      N      O

# Specifications

## OPERATING

**Input Signals** Voltage: +/- 50mV to +/- 10Vdc  
 Current: 4 to 20mA, 10 to 50mA standard  
 Thermocouple: J, K, T, E, R, S, B, C, Nicrosil-Nisil and Nickel-Nickel Moly  
 RTD: 10 ohm Cu, 100, 200, and 500 ohm Pt, and 120 ohm Ni  
 Contact: N.O. or N.C. dry contacts  
 User Programmable Linearizations

**Accuracy** Voltage: +/- 0.05% for 50mV to 10Vdc  
 Current: +/- 0.1% for 1mA to 200mA including shunt resistance  
 RTD: +/- 0.5°C  
 Thermocouple:

THERMOCOUPLE TYPE	MEASUREMENT ACCURACY	CONFORMANCE TO IPTS-68	COMPENSATION ACCURACY
J, K*, T*, E*, N, Ni/Ni-Moly	+/- 0.5°C	+/- 0.5°C	+/- 1°C
R, S, C	+/- 0.5°C	+/- 0.5°C	+/- 1°C
B	+/- 0.5°C	+/- 0.5°C	N/A

\* Accuracy Specifications for T, K, & E T/C's are for temperatures above -140°C.  
 For accuracy specifications below -140°C, contact the factory.

**Input Impedance** >10 megohms for T/C and 50mV, 100mV, 200mV, 1Vdc, and 5Vdc ranges; 110 Kohms for 10Vdc range  
**Input Capacity** 16, 32, or 64 direct inputs (any mix of T/C's, RTD's, mV, V, or current)  
**Scan Rate** Up to 20 points/second (nominal)  
**Common Mode Voltage** 300V peak-to-peak maximum  
**Common Mode Noise Rejection** >120 dB at 50/60 Hz with 1 Kohm source imbalance at 300 V peak-to-peak CMV  
**Normal Mode Noise Rejection** >60 dB at 50/60 Hz

## PRINTER AND CHART

**Writing System** Impact dot matrix with color ribbon cassette  
**Number of Printer Colors** Ten - green, red, blue, black, violet, orange, olive, brown, dark blue, and dark green  
**Chart Speed** Programmable from 0.5"/hr to 60"/hr in 0.25" increments and 5 to 1500 mm/hr in 5mm increments.  
 Normal and alarm chart speeds are separately programmable.  
**Chart Paper** 65 ft. (19.8M) of fanfold paper

## POWER

**Power Requirements** 117Vac +10%, 50/60Hz; 230Vac +10%, 50/60Hz  
**Power Consumption** 60 VA idle; 100 VA printing

## ENVIRONMENTAL

**Operating Temperature** 32° to 113° F (0° to 45° C)  
**Operating Humidity** 15 to 70% RH noncondensing  
**Storage Temperature** -4° to 158° F (-20° to 70° C)  
**Storage Humidity** 0 to 100% RH noncondensing

## WEIGHT

Approximately 52 lbs. (23.6kg.)

## OUTPUT

**Alarm Contacts** One common alarm standard - 1 amp at 117Vac or 26Vdc for resistive loads

## OPTIONS

**Additional Contact Alarms** 8, 16, 24, 32 or 48 Form C with the following contact ratings:  
 Standard - 1 amp at 117Vac or 26Vdc for resistive loads  
 EMI Hardened - 1 amp at 117Vac ±10%  
 0.5 amp at 230Vac ±10%  
 0.4 amp at 250Vdc for resistive loads

**Communication Interface** Switch selectable 20mA, RS232C, RS422 (modified), RS485, or custom

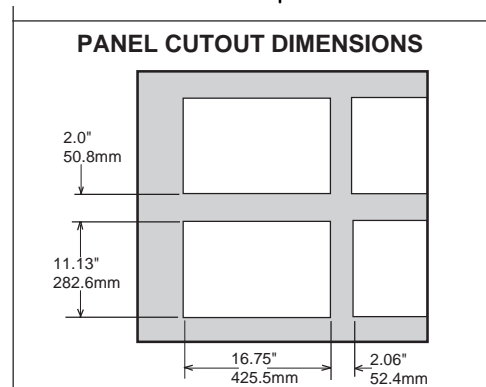
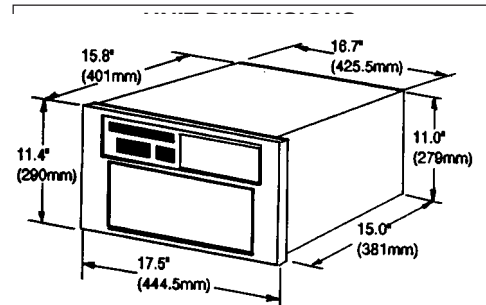

Westronics implementation of new developments and product improvements may result in specification changes in this document.

9303 W. Sam Houston Pkwy. S.  
 Houston, Texas 77099  
 Phone: 713-272-0404 • Fax: 713-272-2273  
<http://www.thermo.com> • e-mail: [sales@thermoflowsystems.com](mailto:sales@thermoflowsystems.com)

